







-  **Trinciatrici per giardini e aree verdi per trattori da 12 a 60 HP**
-  **Compact mulchers for gardens and green areas for tractors from 12 to 60 HP**
-  **Mulchgeräte für Gärten und Grünflächen für Traktoren von 12 bis 60 PS**
-  **Broyeurs pour jardins et espaces verts pour tracteurs de 12 a 60 CV**
-  **Desbrozadoras compactas para jardines y zonas verdes para tractores de 12 a 60 CV**

# MINI



Trinciatrice compatta, da applicare a trattori con potenze comprese tra 12 e 30 HP. Consigliata per la trinciatura di erba su aree verdi, parchi e campi da gioco.



Compact rear mounted grass mulcher, for tractors from 12 to 30 HP. It is suited for mulching light grass on green areas, parks and sport courts.



Kompaktes Gerät für den Gartenbau für Traktoren von 12 bis 30 PS. Es eignet sich zum Mulchen von geringem Bestand auf Grünflächen, Parks und Sportplätzen.



Broyeur postérieur compact pour tracteurs de 12 à 30 CV. Il est conseillé pour broyer l'herbe des espaces verts, parcs et terrains de jeu.



Desbrozadora compacta para tractores con una potencia entre 12 y 30 CV, indicada para la trituración de hierba en parques, zonas verdes y campos deportivos.

Mod.													
	cm	Min	Max	mm	n°	n°	PTO	A	B	C	min	max	
<b>MINI 115</b>	115	12	30	530   620	32	64	3	540	75	129	85	200	250
<b>MINI 125</b>	125	12	30	530   720	34	68	3	540	75	139	85	205	260
<b>MINI 145</b>	145	12	30	615   835	40	80	3	540	75	159	85	220	280



- Attacco fisso e reversibile, Cat. I.
- Fixed and reversible 3-point linkage, Cat. I.
- Fester und umkehrbarer Dreipunktbock, Kat. I.
- Attelage fixe et réversible à 3 points, Cat. I.
- Enganche fijo y reversible a los 3 puntos, Cat. I.



- Rullo livellatore autopulente regolabile in altezza.
- Self-cleaning and adjustable rear roller.
- Einstellbare und selbstreinigende Stützwalze.
- Rouleau palpeur auto-nettoyant, réglable en hauteur.
- Rodillo trasero autolimpiable y regulable en altura.



- Scatola ingranaggi con ruota libera.
- Gearbox with free wheel.
- Getriebe mit Freilauf.
- Boîtier avec roue libre.
- Caja de transmisión con rueda libre.

## OPTIONALS

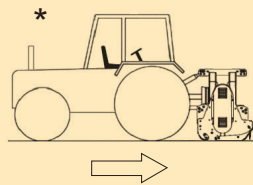

Optional

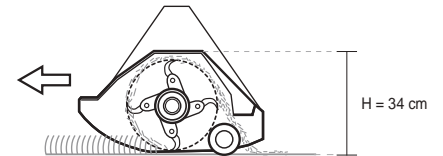

- Scatola ingranaggi con albero passante e/o doppia ruota libera\*.
- Gearbox with through shaft and/or with double free wheel\*.
- Getriebe mit Durchtrieb und/oder doppelter Freilauf\*.
- Boîtier avec arbre de sortie et/ou double roue libre\*.
- Caja de transmisión con eje cardan passante y/o doble rueda libre\*.



- Slitte di appoggio.
- Skids.
- Satz Kufen.
- Jeu patins.
- Patines.



- Ruote frontali stabilizzatrici in gomma, regolabili in altezza (per uso frontale).
- Front rubber wheels, height adjustable (for front/push mode).
- Regulierbare Gummistützräder für Frontanbau.
- Jeu roues frontales en caoutchouc, réglable en hauteur (version avant).
- Ruedas frontales en goma, regulables en altura (para uso frontal).



- Albero cardanico.
- Pto drive shaft.
- Gelenkwelle.
- Arbre cardan.
- Eje cardan.

# GREEN



**HARDOX®**  
WEAR PLATE



Trinciatrice compatta reversibile, da applicare a trattori con potenze comprese tra 30 e 55 HP. Consigliata per la trinciatura di erba e ramaglia fino a Ø 2-3 cm. su aree verdi, parchi e campi da gioco.



Broyeur réversible compact pour tracteurs de 30 à 55 CV. Il est conseillé pour broyer l'herbe et les tiges allant jusqu'à Ø 2-3 cm, des espaces verts, parcs et terrains de jeu.











Front and rear compact mulcher to fit tractors' from 30 to 55 HP. It is suited for mulching light grass and bushes of Ø 2-3 cm on green areas, parks and sport courts.



Desbrozadora reversible para tractores con una potencia entre 30 y 55 CV, indicada para la trituración de hierba y ramaje hasta Ø 2-3 cm en parques, zonas verdes y campos deportivos.

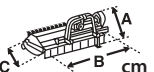

Heck und Frontanbau Gerät für den Gartenbau für Traktoren von 30 bis 55 PS. Es eignet sich zum Mulchen von Gras und Reisig bis Ø 2-3 cm auf Grünflächen, Parks und Sportplätzen.

Mod.												
	cm	Min	Max	mm	n°	n°	PTO	A	B	C	min	max
<b>GREEN 115</b>	115	30	55	750   400	32	2	540 (1000)	80	130	95	250	300
				430   720								
<b>GREEN 125</b>	125	30	55	750   500	34	2	540 (1000)	80	140	95	270	320
				430   820								
<b>GREEN 145</b>	145	30	55	805   645	40	2	540 (1000)	80	160	95	295	345
				485   965								
<b>GREEN 160</b>	160	30	55	885   715	44	2	540 (1000)	80	175	95	315	365
				565   1035								
<b>GREEN 180</b>	180	30	55	885   915	50	2	540 (1000)	80	195	95	345	395
				565   1235								



- Attacco spostabile meccanicamente e reversibile, su tubi cromati, Cat. I.
- Displaceable and reversible 3-point linkage, on chromate tubes, Cat. I (mechanical).
- Versetzbarer (mechanisch) und umkehrbarer Dreipunktbock, Kat. I, an verchromten Rohren.
- Attelage déportable et réversible à 3 points, avec tuyaux chromés, Cat. I (mécanique).
- Enganche desplazable y reversible a los 3 puntos sobre tubos cromados,, Cat. I (desplazamiento mecánico).



- Rullo livellatore autopulente regolabile in altezza.
- Self-cleaning and adjustable rear roller.
- Einstellbare und selbstreinigende Stützwalze.
- Rouleau palpeur auto-nettoyant, réglable en hauteur.
- Rodillo trasero autolimpiable y regulable en altura.



- Scatola ingranaggi con ruota libera e albero passante.
- Gearbox with free wheel and through shaft.
- Getriebe mit Freilauf und Durchtrieb.
- Boîtier avec roue libre et arbre de sortie.
- Caja de transmisión con rueda libre y eje cardan pasante.



- PTO 540/1000 g/min (invertendo le pulegge).
- PTO 540/1000 rpm (reversing the pulleys).
- Getriebe 540 oder 1000 U/min (Umkehrbare Riemenscheibe).
- PDF 540/1000 t/min (en inversant les poulies).
- PTO 540/1000 g/min (invertiendo las poleas).

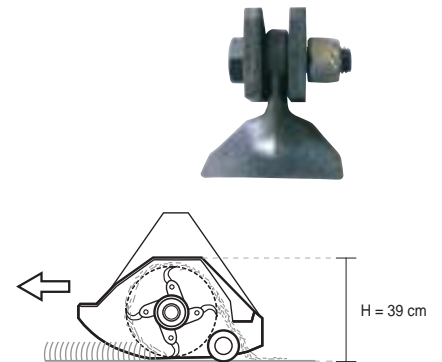
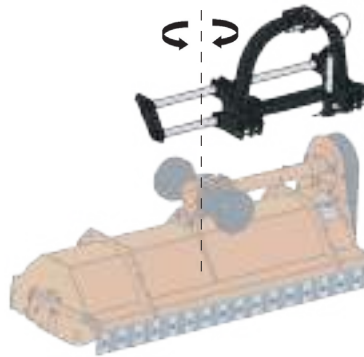

## OPTIONALS



- Spostamento idraulico con tubi e innesti rapidi.
- Hydraulic side shift with hoses and quick couplings.
- Hydraulische Seitenverschiebung.
- Déport hydraulique avec tuyaux et prises rapides.
- Desplazamiento hidráulico.



- Scatola 2000 g/min. con ruota libera e albero passante (per uso frontale).
- 2000 rpm gearbox with free wheel and through shaft (for front PTO).
- Getriebe 2000 U/min mit Freilauf und Durchtrieb (Frontanbau).
- Boîtier 2000 t/min avec roue libre et arbre de sortie (pour PDF frontale).
- Caja 2000 g/min con doble rueda libre y árbol pasante (para PTO frontal).



- Doppia ruota libera e albero passante nella scatola ingranaggi\*.
- Double free wheel and through shaft in the gearbox\*.
- Doppelter Freilauf und Durchtrieb im Getriebe\*.
- Double roue libre et arbre de sortie dans le boîtier\*.
- Doble rueda libre y árbol pasante dentro de la caja engranajes\*.

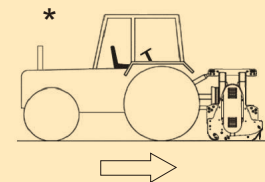

- Slitte di appoggio.
- Skids.
- Satz Kufen.
- Jeu patins.
- Patines.



- Ruote frontali stabilizzatrici in gomma, regolabili in altezza (per uso frontale).
- Front rubber wheels, height adjustable (for front/push mode).
- Regulierbare Gummistützräder für Frontanbau.
- Jeu roues frontales en caoutchouc, réglable en hauteur (version avant).
- Ruedas frontales en goma, regulables en altura (para uso frontal).





- Albero cardanico.
- Pto drive shaft.
- Gelenkwelle.
- Arbre cardan.
- Eje cardan.

# PARK/P













 Trinciatrice compatta da applicare a trattori con potenze comprese tra 20 e 60 HP. Consigliata per lo sfalcio di erba cespugli e ramaglia fino a  $\varnothing$  2-3 cm su parchi, aree verdi, campi da gioco.

 Compact rear mounted mulcher, for tractors from 20 to 60 HP. It is suited to mulch grass, bushes and light pruning of  $\varnothing$  2-3 cm on parks, green areas, sport courts, etc.

 Kompaktes Gerät für Traktoren von 20 bis 60 PS. Es eignet sich zum Mulchen von Gras und Reisig bis  $\varnothing$  2-3 cm auf Parks, Grünfläche, Sportplätzen, etc.

 Broyeur postérieur compact pour tracteurs de 20 à 60 CV. Il est conseillé pour broyer l'herbe, les buissons et les tiges allant jusqu'à  $\varnothing$  2-3 cm dans les parcs, les espaces verts, les terrains de jeu, etc.

 Desbrozadora compacta para tractores con una potencia entre 20 y 60 CV, indicada para la trituración de hierba, arbustos y restos de poda (hasta 2-3 cm.  $\varnothing$ ) en parques, zonas ver-des y campos deportivos.

Mod.													
	cm	Min	Max	mm	n°	n°	n°	PTO	A	B	C	min	max
<b>PARK/P 105</b>	105	20	60	590   460 270   780	10	30	2	540 (1000)	79	120	80	265	320
<b>PARK/P 115</b>	115	20	60	590   560 270   880 690   560	10	30	2	540 (1000)	79	130	80	280	340
<b>PARK/P 125</b>	125	20	60	370   880 775   575	12	36	2	540 (1000)	79	140	80	295	350
<b>PARK/P 135</b>	135	20	60	455   895 775   675	12	36	2	540 (1000)	79	150	80	310	360
<b>PARK/P 145</b>	145	20	60	455   995 875   715	14	42	2	540 (1000)	79	160	80	320	375
<b>PARK/P 160</b>	160	20	60	555   1045 875   915	14	42	2	540 (1000)	79	175	80	355	405
<b>PARK/P 180</b>	180	20	60	555   1245	16	48	3	540 (1000)	79	195	80	370	430



- Attacco spostabile meccanicamente, Cat. I.
- Displaceable three point linkage, Cat. I (mechanical).
- Versetzbarer Dreipunktbock, Kat. I (mechanischer).
- Attelage déportable à 3 points, Cat. I (mécanique).
- Enganche a los 3 puntos del tractor desplazable, Cat. I (desplazamiento mecánico).



- Scatola ingranaggi con ruota libera.
- Gearbox with free wheel.
- Getriebe mit Freilauf.
- Boîtier avec roue libre.
- Caja de transmisión con rueda libre.



- Rullo livellatore autopulente regolabile in altezza.
- Self-cleaning and adjustable rear roller.
- Einstellbare und selbstreinigende Stützwalze.
- Rouleau palpeur auto-nettoyant, réglable en hauteur.
- Rodillo trasero autolimpiable y regulable en altura.



Optional

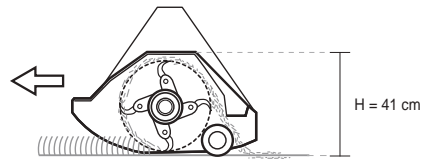

## OPTIONALS



- Spostamento idraulico con tubi e innesti rapidi.
- Hydraulic side shift with hoses and quick couplings.
- Hydraulische Seitenverschiebung.
- Déport hydraulique avec tuyaux et prises rapides.
- Desplazamiento lateral de accionamiento hidráulico.



- Slitte d'appoggio.
- Skids.
- Satz Kufen.
- Jeu patins.
- Patines.



- Albero cardanico.
- Pto drive shaft.
- Gelenkwelle.
- Arbre cardan.
- Eje cardan.



# bertima.it



MINI



GREEN



PARK/P

Le illustrazioni e i dati del presente catalogo sono indicative e non vincolanti per il costruttore • All pictures and data above are indicative only and not binding for the manufacturer • Alle in diesem Katalog enthaltenen Angaben und Zeichnungen sind annehmend und unverbindlich • Toutes les données insérées dans ce catalogue ont été indiquées seulement à titre de renseignement • Las fotografías y los datos mostrados son meramente indicativos y podrían ser variados sin previo aviso por el fabricante.



**BERTI**<sup>®</sup>  
MACCHINE AGRICOLE



Via Musi, 1/A-3-4 - 37042 Caldiero (VR) ITALY  
Tel. +39.045.6139711 - Fax +39.045.6150251  
info@bertima.it



 **MADE IN ITALY**

D006.12 REV.04 - 07.09.2021